



## Model 20S Fire Skid Specification



A Division of MTECH, Inc.  
1072 Marauder, Suite 210  
Chico, CA 95973  
1.888.797.5100  
[www.qtacfire.com](http://www.qtacfire.com)  
[www.mtechincorporated.com](http://www.mtechincorporated.com)



## TANK

The tank shall have the following characteristics:

- MTECH PolyTough™ extrusion-welded Copolymer Polypropylene construction
- Capacity of 20 gallons of water
- 3/8" internal baffles with interlocking design to meet NFPA standards
- Pump suction plumbed to the center of the tank with anti-cavitation device
- 1-1/2" tank drain
- Threaded 6" fill well, flush mounted at top of tank
- Tank vent
- Site tube to gauge water level
- Tie down points and flange-mounted anchor points to secure the skid unit
- Integral hose rack

## PUMP & ENGINE

The pump system shall have the following characteristics:

- Honda GX25 1.0hp engine with recoil start and Koshin 1" self-priming centrifugal pump
- 1" auxiliary suction
- 5/8" to hose rack
- 1" tank to pump
- Cooling return so that discharge can be completely stopped without causing a risk for pump overheating
- All plumbing to be of either composite polypropylene, brass, or stainless steel

## FOAM

The foam system shall have the following characteristics:

- OPTION: End-of-line foam system, includes:
  - Aerating nozzle



## HOSE & ASSOCIATED COMPONENTS

The hose and associated hardware shall have the following characteristics:

- 5/8" X 50' of rubber booster hose
- ¼ turn end-of-line shut-off
- Brass adjustable combination nozzle

## ACCESSORIES

- OPTION: Draft hose kit
- OPTION: Brush guard kit

## WEIGHTS\*

Dry weight: 58 lbs.

Wet weight: 225 lbs.

Additional weight per component:

- Brushguard kit:

*\* All weights are approximate*

# DIMENSIONS

END VIEW

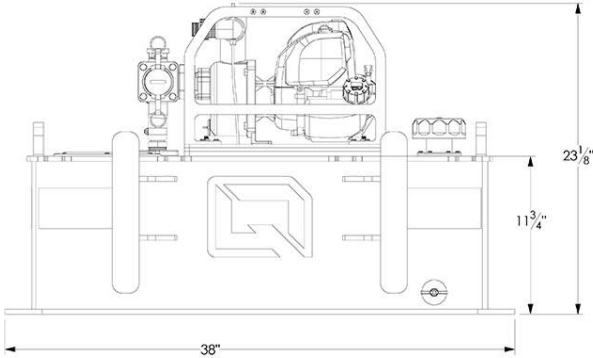

TOP VIEW

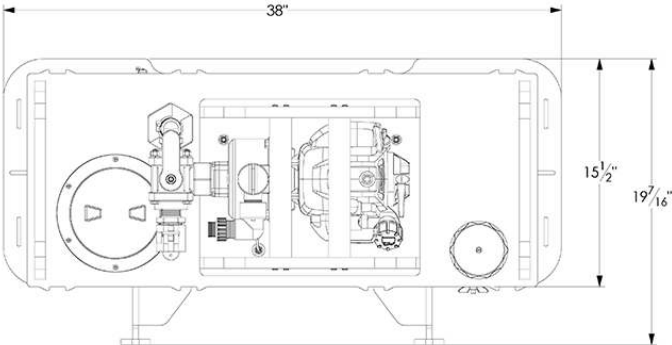

END VIEW

